

# Austin Bench R-5504

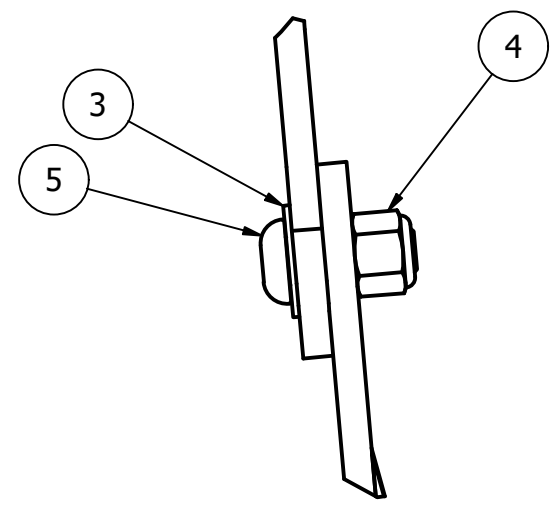

DETAIL A  
SCALE 2 : 3

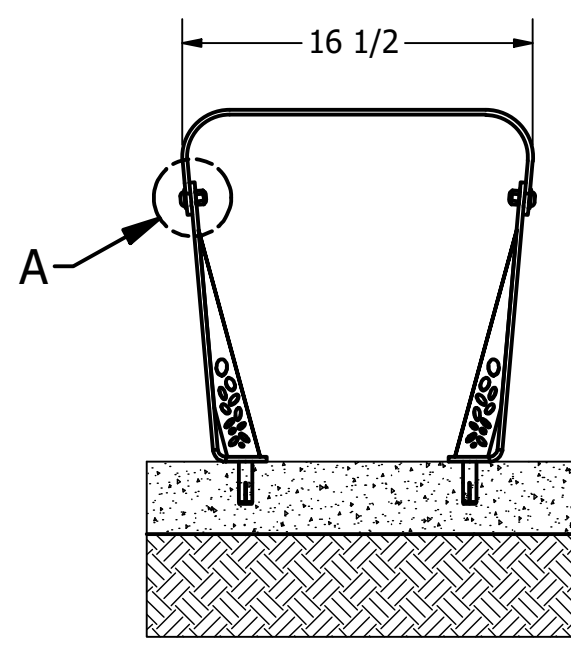
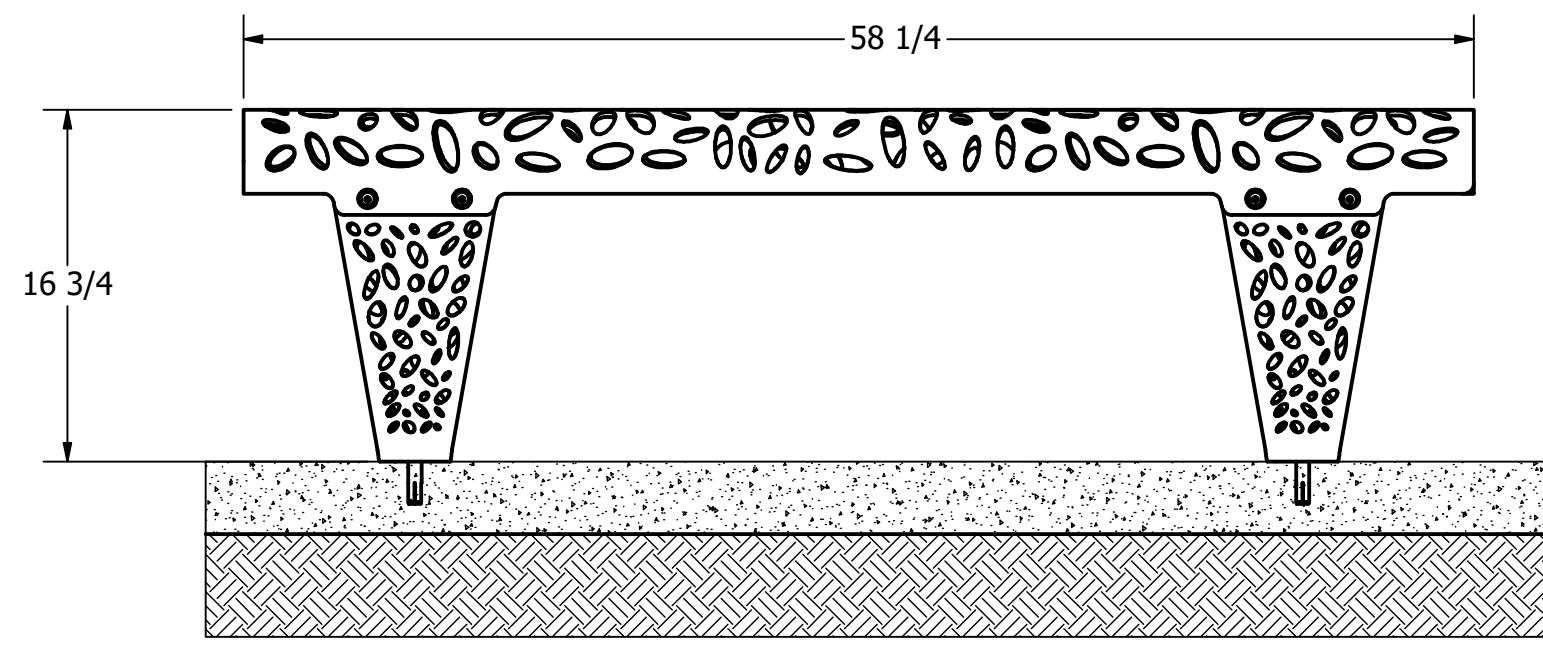
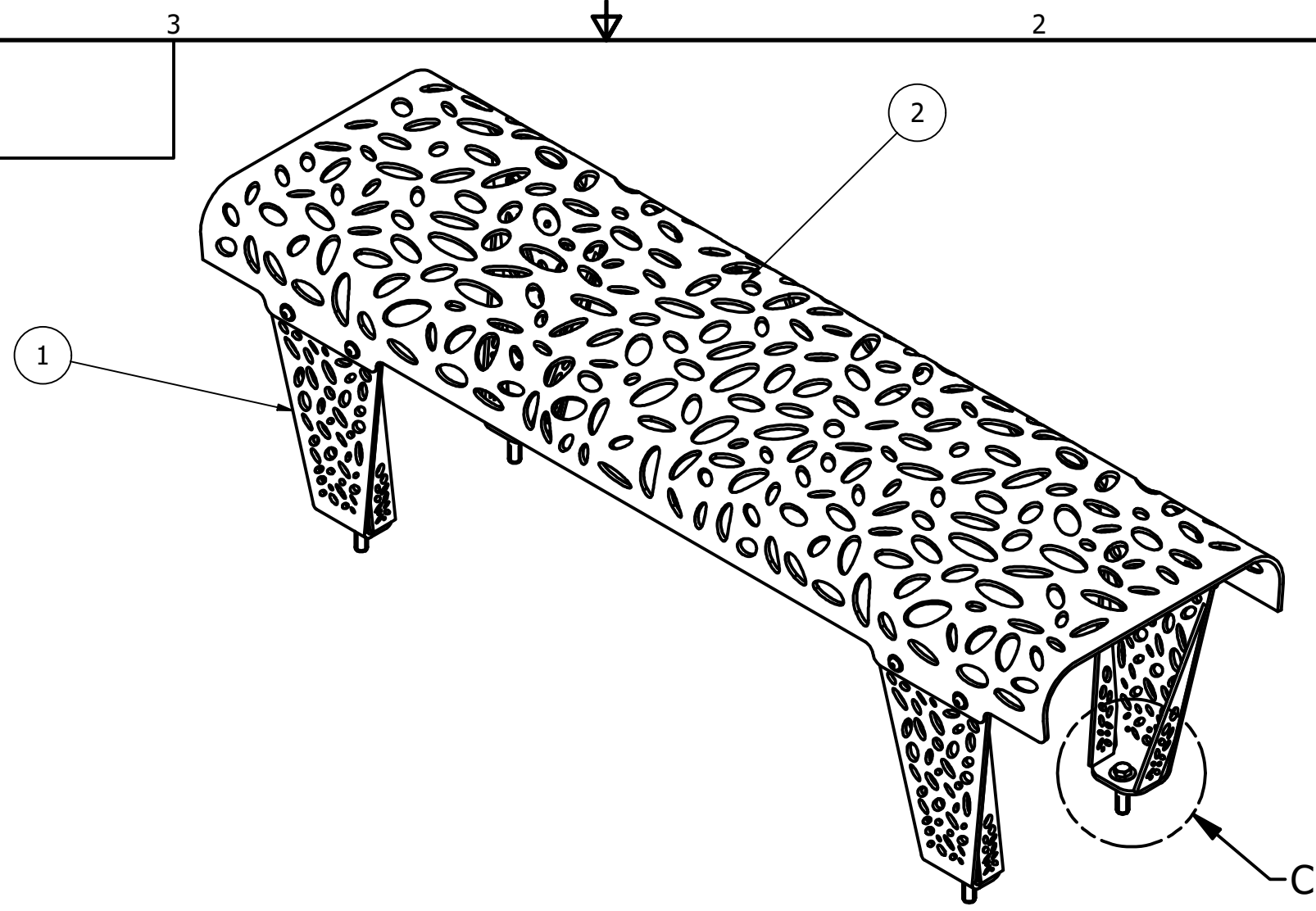

DETAIL B  
SCALE 1 : 2  
4 PLACES

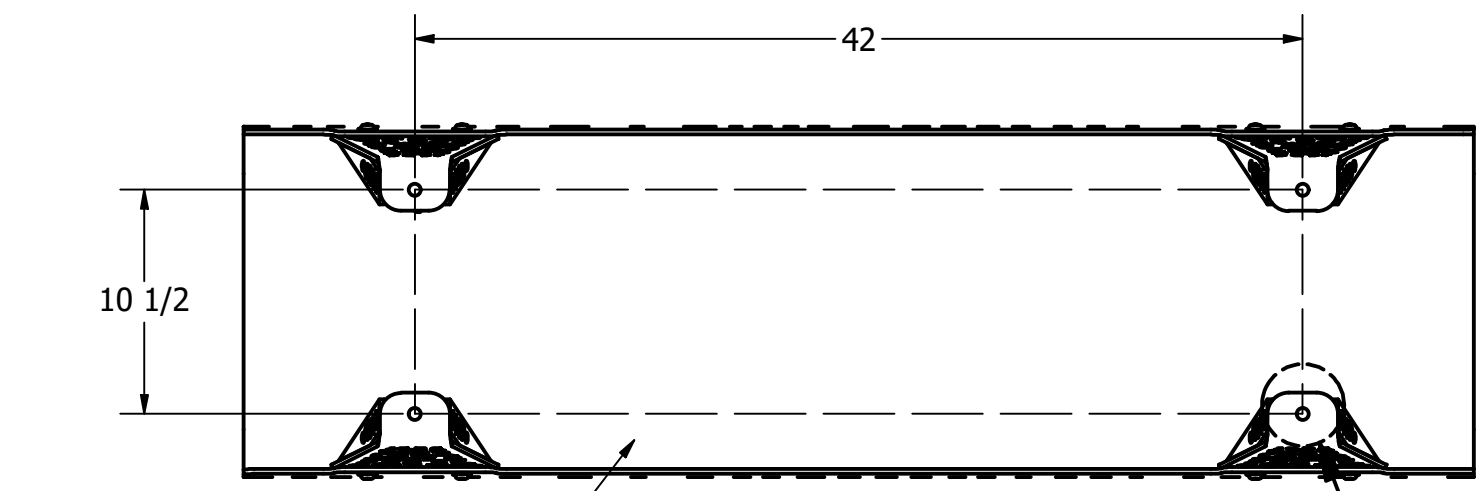

PATTERN HIDDEN FOR CLARITY

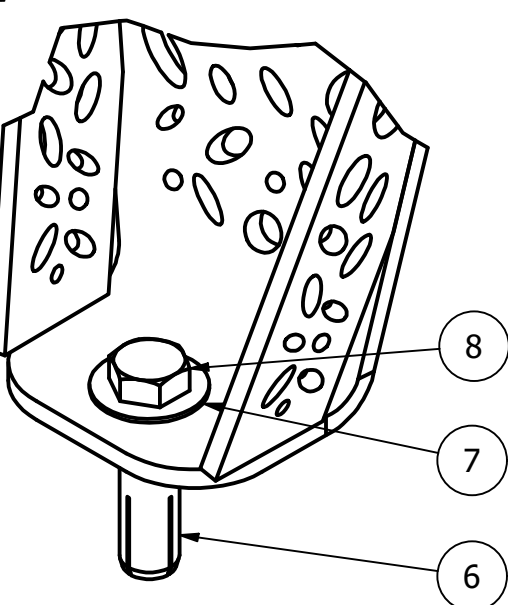
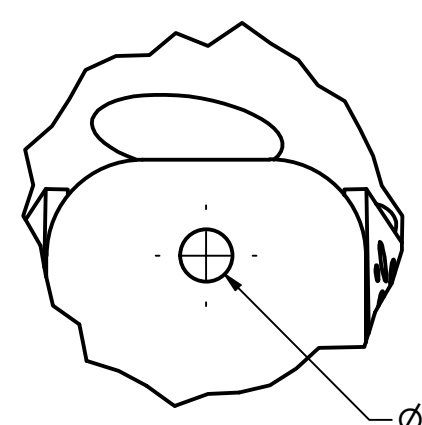

DETAIL C  
SCALE 1 : 2

## General Description:

Reliance Foundry's R-5504 Austin aluminum benches feature modern, laser-cut designs inspired by nature. These versatile backless benches add a touch of elegance to any public space, while fostering a comfortable, social atmosphere. Easy bolt-down installation for indoor or outdoor use. The aluminum construction is designed for durability and long-term wear. Choose standard silver or any RAL color in Reliance Foundry's richly colored and highly protective IronArmor coating.

## Specifications:

Height	: 16 3/4"
Depth	: 16 1/2"
Length	: 58 1/4"
Weight	: 31.5 lbs
Material	: Aluminum 6061

## Finish :

IronArmor Protective Coating

## PARTS LIST

ITEM	QTY	PART NUMBER	DESCRIPTION
1	4	R5504-001	BENCH LEG 5504
2	1	R5504-002	BENCH TOP 5504
3	8		STAINLESS STEEL WASHER 3/8"
4	8		STAINLESS STEEL LOCKNUT 3/8"
5	8		STAINLESS STEEL BUTTON HEAD BOLT 3/8" X 1"
6	4		DROP-IN CONCRETE ANCHOR 1/2"
7	4		STAINLESS STEEL WASHER 1/2"
8	4		HEX HEAD SCREW 1/2" X 1 1/2"

## Notes:

1. Embedment details are for reference illustration only. Minimum foundation sizes depend on local soil weather conditions, and engineering requirements.
2. This drawing is not drawn to scale. Dimensions provided herein is for reference only. Please consult Reliance Foundry sales professionals if any dimension is critical to your particular installation.
3. Reliance Foundry reserves the right to amend design and specifications without prior notice for product improvement.



Unit 207, 6450 - 148 Street, Surrey, BC V3S 7G7, Canada  
1-877-789-3245 info@reliance-foundry.com  
[www.reliance-foundry.com](http://www.reliance-foundry.com)

TITLE			
Austin Bench R-5504			
SIZE	DWG NO	REV	
C	R5504-00	A00	
NOT TO SCALE	SHEET 1 OF 1		