

# Corner Guard Round Edge R-2012

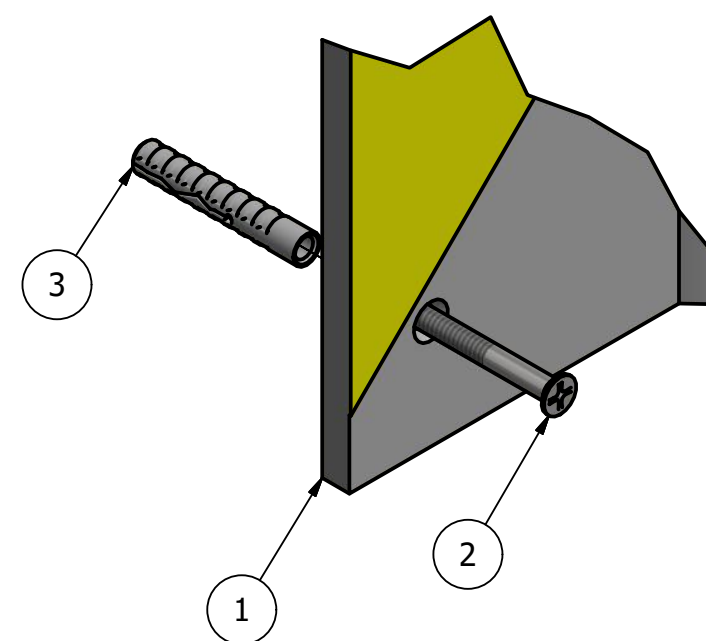
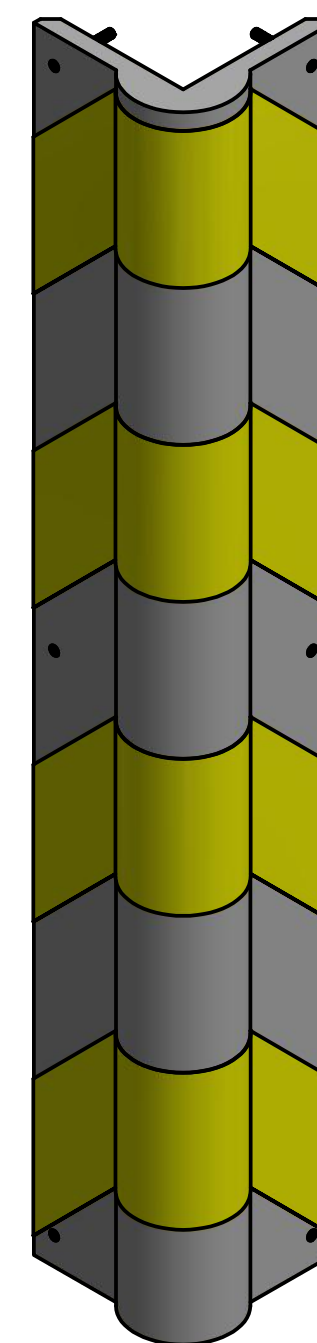
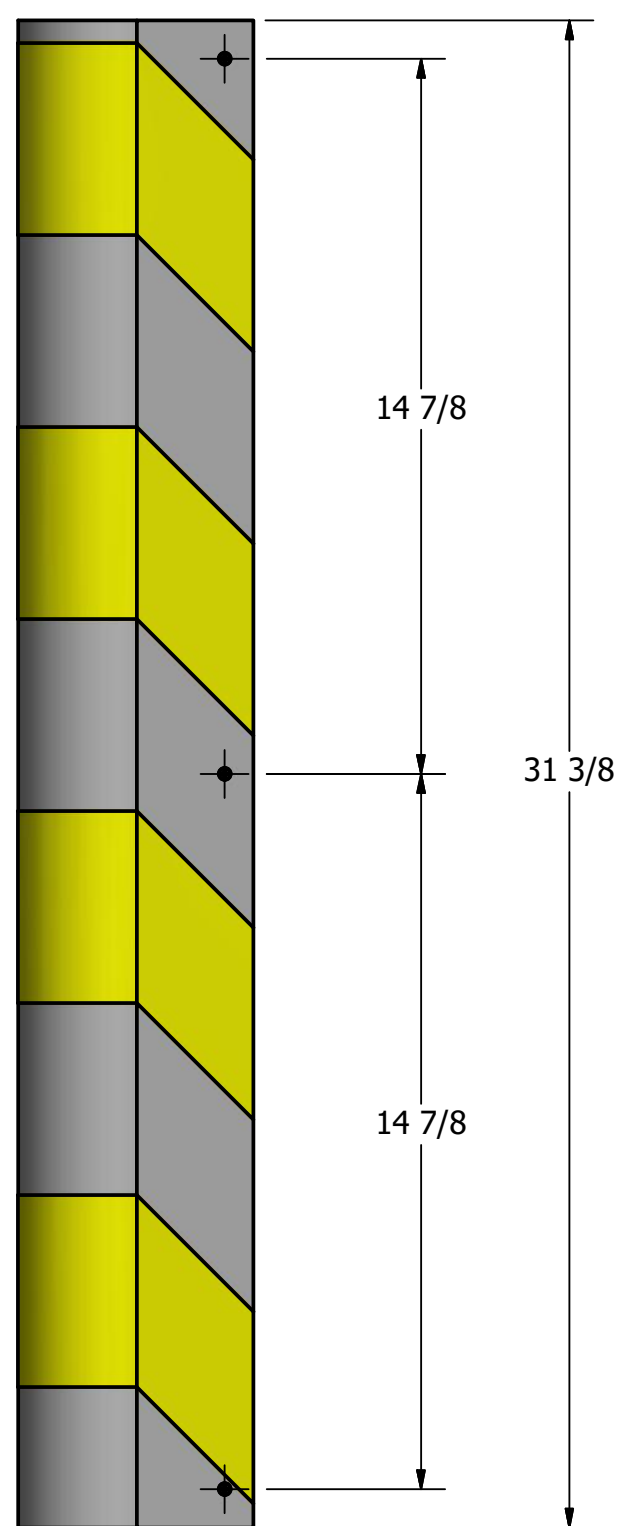
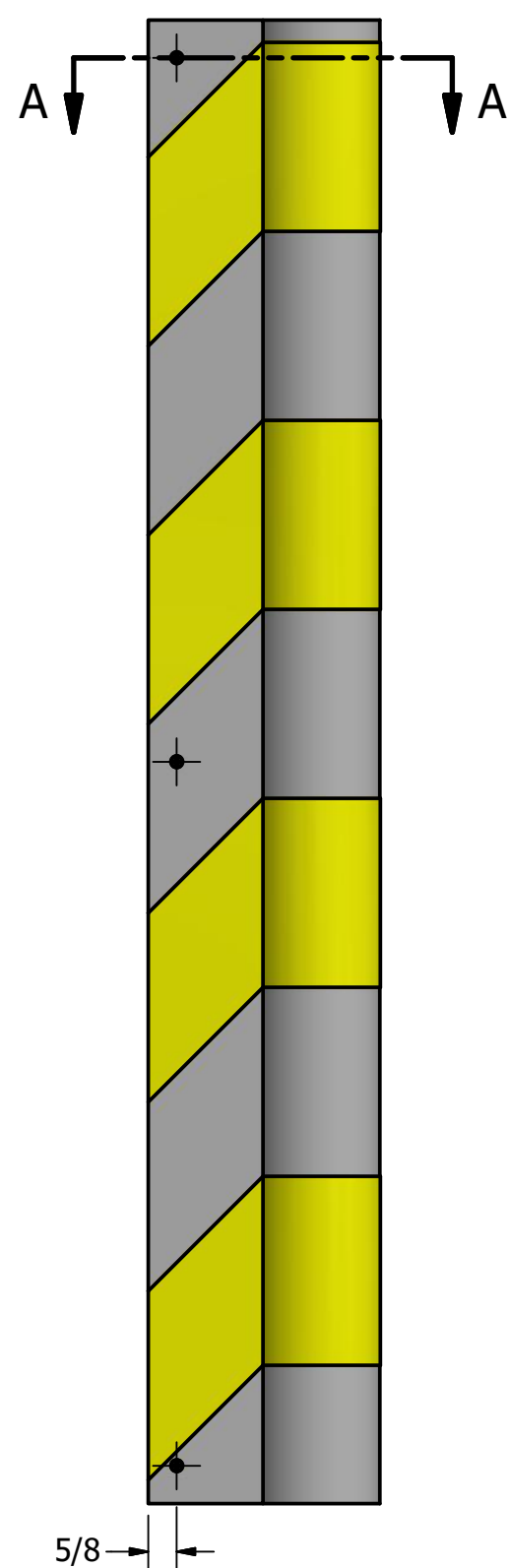
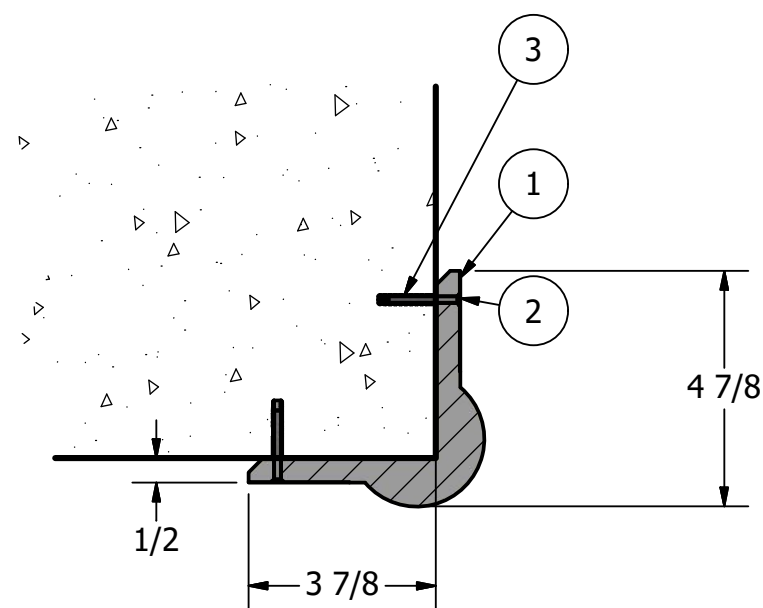

## General Description:

Corner guards protect vehicles and walls. They are space-efficient and ideal for busy or cramped environments such as enclosed parking lots, warehouses, commercial loading docks and various industrial applications. Corner guards feature reflective yellow markings for optimal visibility in all lighting conditions. Rubber is highly durable, form-fitting and won't crack, chip or peel with extended use—even in heavy commercial and industrial environments. Corner guards feature simple bolt-on, surface-mount installation and require minimal labor and equipment to install.

## Specifications:

Length: 31 3/8"

Width: 4 7/8"

Weight: 5 lbs

Material: Recycled Rubber Composite

## Color Selections:

☉ Yellow Stripe on Black: R-2012-YEL-BLK

PARTS LIST					
ITEM	QTY	PART NUMBER	DESCRIPTION	MATERIAL	WEIGHT
1	1	R-2012 Corner Guard	R-2012 Corner Guard w/ Round Edge	Recycled Rubber Composite	5 lbs
2	6	Nylon Drive Screw Anchor - Round Head Phillips Drive Screw	Round Head Phillips Drive Screw - install with hammer, remove with screwdriver	Steel Plated	
3	6	Nylon Drive Screw Anchor - Nylon Shield M6 x 35	Nylon Shield M6 x 35 - requires 6mm x 35mm hole (dia. x depth)	Nylon	

**RELIANCE FOUNDRY**  
SINCE 1925

Unit 207, 6450 - 148 Street, Surrey, BC V3S 7G7, Canada  
1-888-735-5680 info@reliance-foundry.com  
www.reliance-foundry.com

TITLE			
<b>Corner Guard Round Edge R-2012</b>			
SIZE	DWG NO	REV	
C	R2012	C1	