

# Parking Stop, Model R-2003 Series

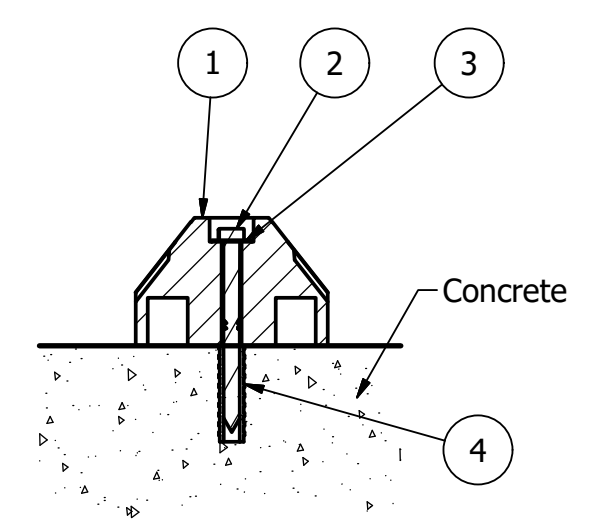
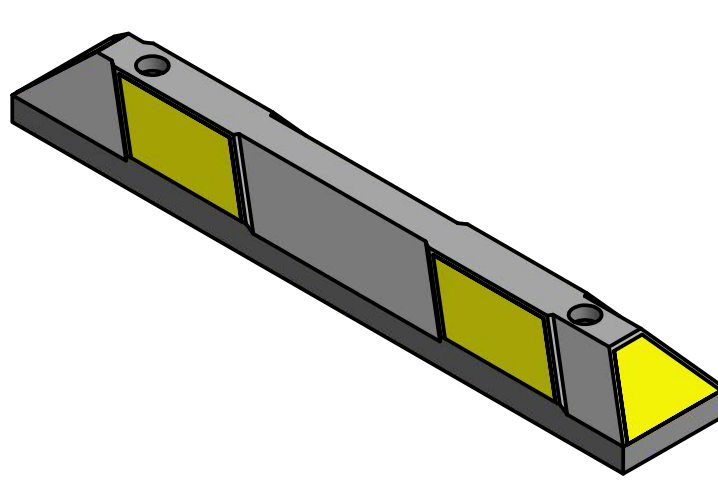
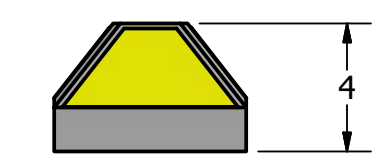
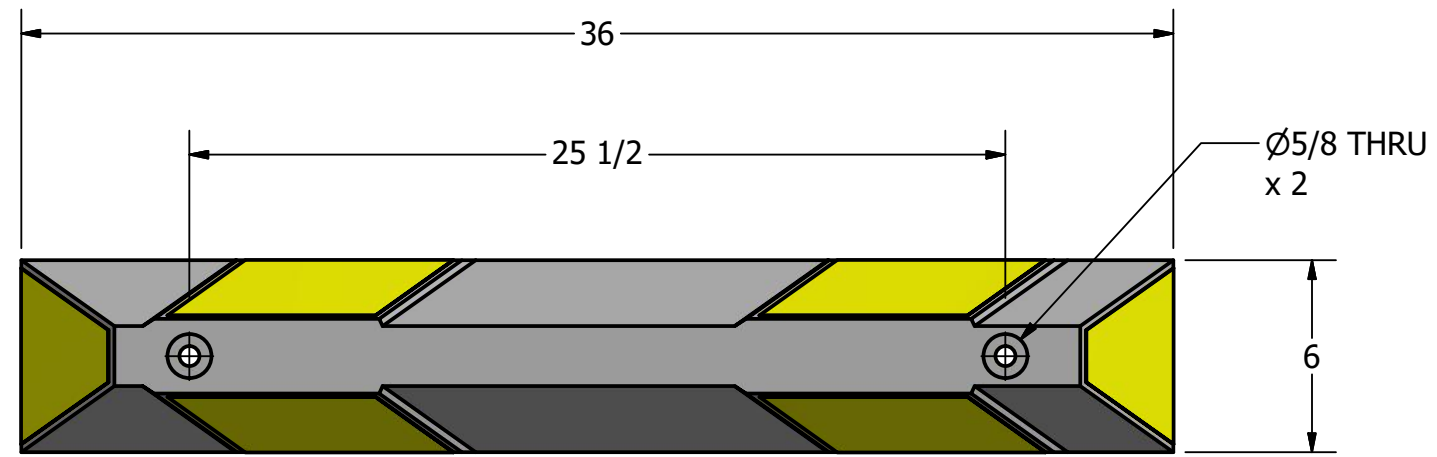

Concrete Installation  
w/ Lag Bolt and Lag Shield

## General Description:

Parking stops indicate how far drivers should pull into a parking stall. They protect vehicles from scraping low bumpers and tailpipes on high curbs. They also prevent intrusion into sidewalks and other pedestrian areas--as well as gardens, utility spaces, exposed walls, windows and other sensitive areas. When installed in parking spaces, curbs prevent vehicles from driving through stalls--helping to ensure loading room for back-in vehicles and minimizing risk of collision between vehicles simultaneously parking opposite each other. Limiting vehicle pull-through ensure more predictable driving greater safety.

## Specifications:

- Length: 36"
- Width: 6"
- Height: 4"
- Weight: 17 lbs
- Material: Recycled Rubber Composite

## Color Selections:

- ☉ Yellow Stripe on Black: R-2003-YEL-BLK

## Installation Options:

- ☉ Concrete Installation w/ Lag Bolt (see sheet 1 of 2)
- Asphalt Installation w/ Rebar Spike (see sheet 2 of 2)



Unit 207, 6450 - 148 Street, Surrey, BC V3S 7G7, Canada  
1-888-735-5680 info@reliance-foundry.com  
www.reliance-foundry.com

TITLE			
<b>Parking Stop R-2003 Series</b>			
SIZE	DWG NO	REV	
C	R2003	C1	
NOT TO SCALE		SHEET 1 OF 2	

PARTS LIST					
ITEM	QTY	PART NUMBER	DESCRIPTION	MATERIAL	WEIGHT
1	1	R2003	R2003 3' Rubber Parking Stop	Compression Molded Recycled Rubber Composite	17 lbs
2	2	Hex Lag Bolt 1/2" x 6"	Hex Lag Bolt 1/2" x 6" - requires 3/4" wrench (socket)	Steel HDG	1/4 lbs
3	2	Washer 1/2"	Washer 1/2" OD 1 1/4" Thick .05"	Steel Plated	
4	2	Lag Bolt Shield 1/2" x 3"	Lag Bolt Shield 1/2" x 3" - requires 3/4" x 3" hole (dia. x depth)	Steel HDG	1/8 lbs

# Parking Stop, Model R-2003 Series

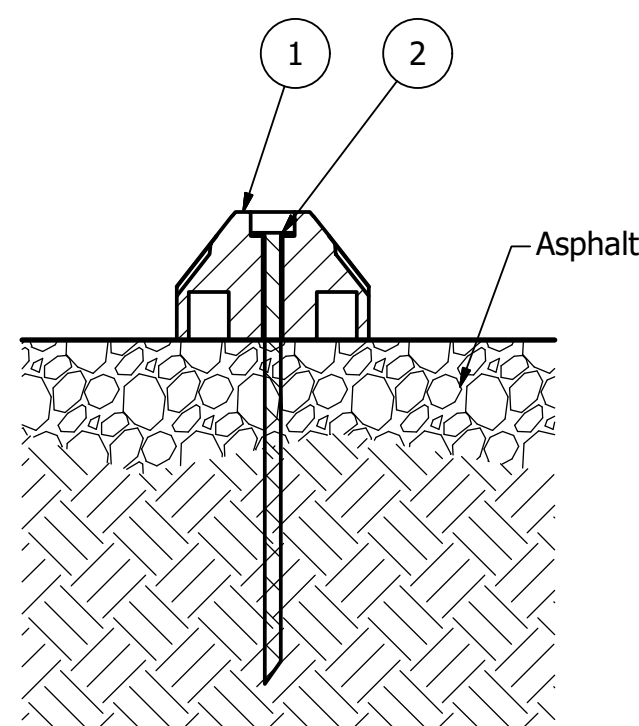
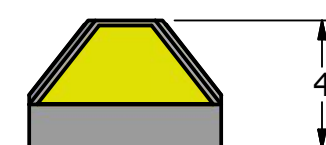
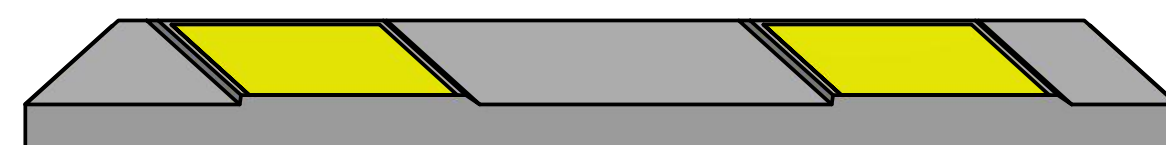
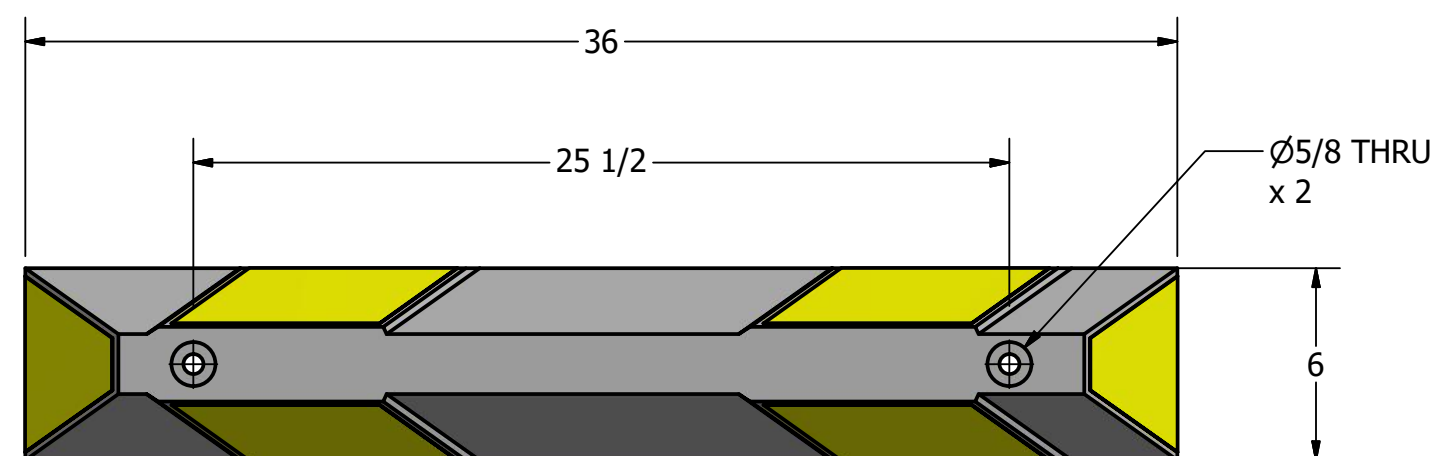

Asphalt Installation  
w/ Rebar Spike

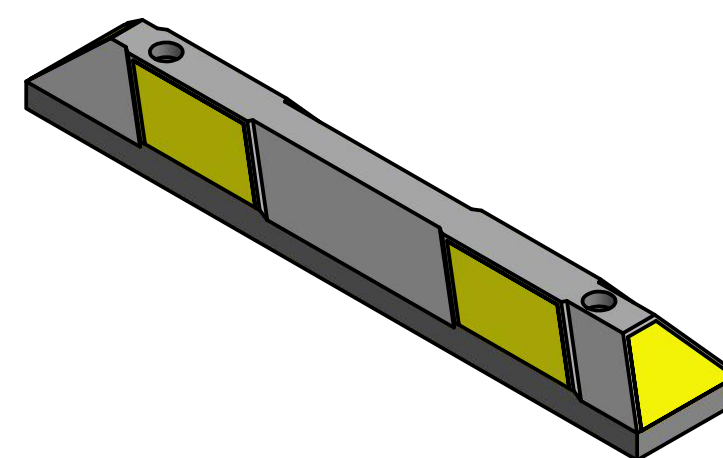

## General Description:

Parking stops indicate how far drivers should pull into a parking stall. They protect vehicles from scraping low bumpers and tailpipes on high curbs. They also prevent intrusion into sidewalks and other pedestrian areas--as well as gardens, utility spaces, exposed walls, windows and other sensitive areas. When installed in parking spaces, curbs prevent vehicles from driving through stalls--helping to ensure loading room for back-in vehicles and minimizing risk of collision between vehicles simultaneously parking opposite each other. Limiting vehicle pull-through ensure more predictable driving greater safety.

## Specifications:

Length: 36"

Width: 6"

Height: 4"

Weight: 17 lbs

Material: Recycled Rubber Composite

## Color Selections:

- ⊙ Yellow Stripe on Black: R-2003-YEL-BLK

## Installation Options:

- Concrete Installation w/ Lag Bolt (see sheet 1 of 2)
- ⊙ Asphalt Installation w/ Rebar Spike (see sheet 2 of 2)

**RELIANCE FOUNDRY**  
SINCE 1925

Unit 207, 6450 - 148 Street, Surrey, BC V3S 7G7, Canada  
1-888-735-5680 info@reliance-foundry.com  
www.reliance-foundry.com

TITLE

**Parking Stop R-2003 Series**

PARTS LIST					
ITEM	QTY	PART NUMBER	DESCRIPTION	MATERIAL	WEIGHT
1	1	R2003	R2003 3' Rubber Parking Stop	Compression Molded Recycled Rubber Composite	17 lbs
2	2	Rebar Spike 1/2" - 14"	Rebar Spike 1/2" - 14"	Steel HDG	3/4 lbs

SIZE  
**C**

DWG NO  
**R2003**

REV  
**C1**